



## Temperature Products

# Model BACO 2" Back Connected Industrial Bimetallic Thermometers

# New!

**MADE IN USA**

### DESCRIPTION

U.S. Gauge offers 2" heavy duty, industrial bimetallic thermometers with a standard rear 1/4-18 NPT connection. These thermometers, with 304 stainless steel construction, are rugged and commonly used in light industrial and OEM applications. The thermometers may be silicone filled for additional vibration dampening.

A variety of lens materials are available including acrylic, polycarbonate, and tempered glass. Standard stem diameter, up to 42" long, is .25". Other available stem sizes are .24" (6 mm), and .375" (9.52 mm).

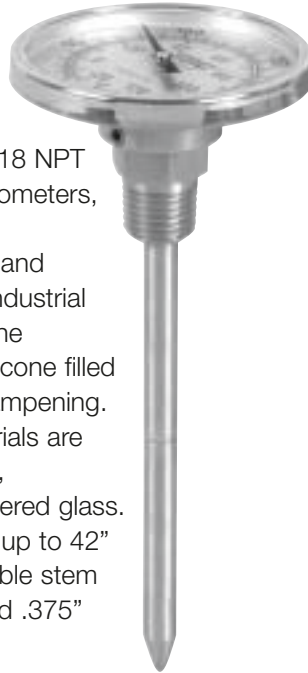

### SPECIFICATIONS

STEM DIAMETER: .25" standard up to 42" stem

CONNECTION: 1/4-18 NPT

EXTERNAL RESET: Easy to calibrate by loosening the socket head screw (above hex connecting nut) with 5/64" hex wrench

CONSTRUCTION: 304 stainless steel external parts, welded construction; corrosion resistant to most chemicals

HERMETIC SEAL: Per ASME B40.3, dustproof and leakproof

DIAL: Anodized aluminum with large black numbers and graduations

LENS: Glass

BIMETALLIC COIL: Helix coil is silicone coated on ranges below 500°F for vibration dampening and to maximize heat transfer and response time

ACCURACY:  $\pm 1\%$  full span per ASME B40.3 Grade A

OVER TEMPERATURE LIMITS: Up to 250°F, 100%; 250° to 550°F, 50%; 550° to 1000°F, continuous use up to 800°F, intermittent use over 800°F

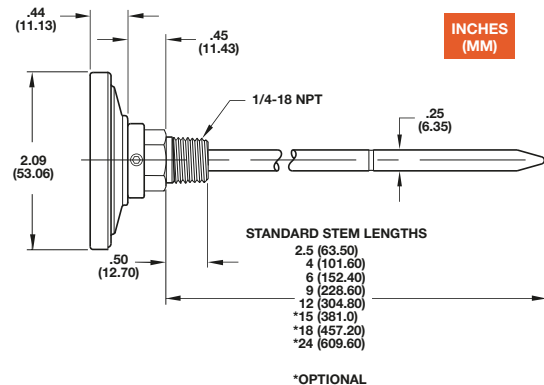

### SPEC NUMBER SELECTION CHART

#### Model BACO-2

#### 2" Dial Size

Connection	Temperature Range*	2-1/2" Stem Length	4" Stem Length	6" Stem Length	9" Stem Length	12" Stem Length
		Spec No.	Spec No.	Spec No.	Spec No.	Spec No.
1/4-18 NPT	0 to 250 FC	415151	415153	415155	415157	415159
	50 to 550 FC	415152	415154	415156	415158	415160

\* All dials are dual scale, Fahrenheit outer scale, Celsius inner scale

© 2002, by AMETEK, Inc. All rights reserved. 15M1102A (160126) Specifications are subject to change without notice. Visit our Web sites for the most up-to-date information.

For Gauges/Thermometers:  
**U.S. GAUGE**  
 820 Pennsylvania Blvd.  
 Feasterville, PA 19053 U.S.A.  
 Tel: (215) 355-6900  
 Fax: (215) 354-1802  
 www.ametekusg.com

Customer Service Tel: (863) 534-1504  
 Customer Service Fax: (863) 533-7465

For Electronic Products:  
**PMT PRODUCTS**  
 820 Pennsylvania Blvd.  
 Feasterville, PA 19053 U.S.A.  
 Tel: (215) 355-6900  
 Fax: (215) 354-1800  
 www.ametekusg.com

For Diaphragm Seals:  
**M&G PRODUCTS**  
 8600 Somerset Drive  
 Largo, FL 33773 U.S.A.  
 Tel: (727) 536-7831  
 Fax: (727) 539-6882  
 www.ametek.com/tci

ISO 9001 REGISTERED MANUFACTURER