



Special Application Gauges

C-1706K Ammonia Refrigerant Gauges

DESCRIPTION

2-1/2" and 3-1/2" steel case gauges, usually installed in ammonia refrigeration systems, these C-1706 compound gauges can also be used to handle other chemicals not injurious to wetted parts. The silicone dampened movement greatly extends gauge life, particularly on tough services like ammonia compressors. Temperature equivalent scale in red provides easy analysis of refrigeration systems.



SPECIFICATIONS

- SIZE: 2-1/2", 3-1/2"
- CASE: Drawn steel, black corrosion-resistant paint
- WINDOW: Threaded, polycarbonate standard (photograph shown with optional steel ring)
- POINTER: Aluminum, adjustable, black finish
- DIAL: Steel, white background with black markings. Refrigerant temperature scale in red
- MOVEMENT: Silicone with glass filled nylon link and stainless steel link rivets
- BOURDON TUBE: 316 stainless steel, soft soldered
- CONNECTION: 1/4-18 NPT, LM, steel
- RANGES: 30" Hg VAC, 0 to 150 psi; 30" Hg VAC, 0 to 300 psi
- ACCURACY: ±3-2-3% of span (Grade B)

SPEC NUMBER SELECTION CHART

Model C-1706K Gauges

| Range | 2-1/2" | 3-1/2" |
|----------|----------------------------|----------------------------|
| | 1/4-18 ANPT LM Spec No. | 1/4-18 ANPT LM Spec No. |
| 30-0-150 | 034272 | 034275 |
| 03-0-300 | 034273 | 034276 |

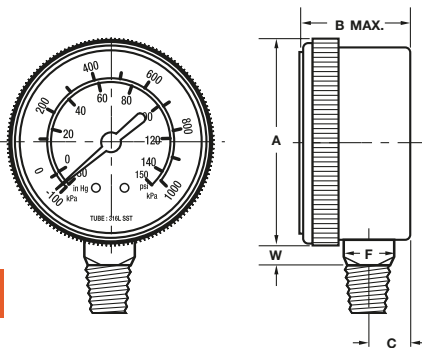

INCHES
(MM)

| DIAL SIZE | UNIT | ØA | B MAX. | C | F | W |
|-----------|--------|------|--------|------|------|------|
| 2-1/2" LM | inches | 2.84 | 1.20 | 0.42 | 0.55 | 0.21 |
| | mm | 72.0 | 30.5 | 10.8 | 14.0 | 5.4 |
| 3-1/2" LM | inches | 3.85 | 1.24 | 0.41 | 0.55 | 0.44 |
| | mm | 97.8 | 31.5 | 10.4 | 14.0 | 11.2 |

© 2002, by AMETEK, Inc. All rights reserved. 15M1102A (160126) Specifications are subject to change without notice. Visit our Web sites for the most up-to-date information.



For Gauges/Thermometers:
U.S. GAUGE
 820 Pennsylvania Blvd.
 Feasterville, PA 19053 U.S.A.
 Tel: (215) 355-6900
 Fax: (215) 354-1802
 www.ametekusg.com

Customer Service Tel: (863) 534-1504
 Customer Service Fax: (863) 533-7465

For Electronic Products:
PMT PRODUCTS
 820 Pennsylvania Blvd.
 Feasterville, PA 19053 U.S.A.
 Tel: (215) 355-6900
 Fax: (215) 354-1800
 www.ametekusg.com

For Diaphragm Seals:
M&G PRODUCTS
 8600 Somerset Drive
 Largo, FL 33773 U.S.A.
 Tel: (727) 536-7831
 Fax: (727) 539-6882
 www.ametek.com/tci

