

Special Application Gauges

Series 1785 Manifold Pressure Test Gauges

DESCRIPTION

Model 1785 2-1/2" Manifold Pressure Test gauges offer several ranges for use with various types of refrigerants, including R-12, R-22, R-502, R-134A, and R-410A. The gauges can be permanently mounted in cooling systems or used on portable manifolds.

Type CR-1780 is supplied with 350 psi retard scale to accommodate accidental over-pressure. All gauges feature a one piece polycarbonate ring and window. This provides quick, easy access to internal front adjusting screw for resetting the pointer.

Gauges are available in English, dual scale, or metric only ranges.



SPECIFICATIONS

- SIZE: 2-1/2"
- CASE: ABS. (P-1785, red; CR-1785, blue)
- RING AND WINDOW: Threaded, polycarbonate
- POINTER: Aluminum, black finish
- DIAL: Steel, white background with black markings. Refrigerant temperature scales in red
- MOVEMENT: Brass, silicone treated
- BOURDON TUBE: P-1785, CR-1785 – Phosphor bronze
- CONNECTION: 1/8-27 NPT LM, brass
- RANGES:
 - P-1785: 0-500 psi, 0-800 psi
 - CR-1785: 30" Hg VAC, 0-120 psi retarded to 350 psi; 30" Hg VAC, 0-250 psi retarded to 500 psi
- ACCURACY: $\pm 3-2-3\%$ of span (Grade B), applies to non-retard portion

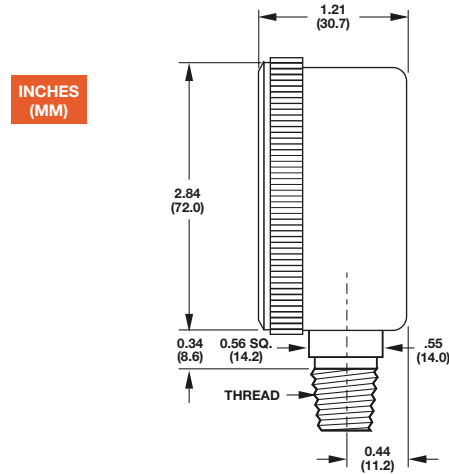

SPEC NUMBER SELECTION CHART

Model Number	Description	Spec No.
CR1785	30" 0 - 120/350 psi, R-12, R-22, R502 temperature scale	169128
P1785	0 - 500 psi, R-12, R-22, R502 temperature scale	169129
CR1785	30" 0 - 120/350 psi, R-134A temperature scale in °F and °C	169130
P1785	0 - 500 psi, R-134A temperature scale in °F and °C	169131
CR1785	30" 0 - 250/500 psi, R-410A temperature scale in °F and °C	169132
P1785	0 - 800 psi, R-410A temperature scale in °F and °C	169133

© 2002, by AMETEK, Inc. All rights reserved. 15M1102A (160126) Specifications are subject to change without notice. Visit our Web sites for the most up-to-date information.



For Gauges/Thermometers:
U.S. GAUGE
 820 Pennsylvania Blvd.
 Feasterville, PA 19053 U.S.A.
 Tel: (215) 355-6900
 Fax: (215) 354-1802
 www.ametekusg.com

Customer Service Tel: (863) 534-1504
 Customer Service Fax: (863) 533-7465

For Electronic Products:
PMT PRODUCTS
 820 Pennsylvania Blvd.
 Feasterville, PA 19053 U.S.A.
 Tel: (215) 355-6900
 Fax: (215) 354-1800
 www.ametekusg.com

For Diaphragm Seals:
M&G PRODUCTS
 8600 Somerset Drive
 Largo, FL 33773 U.S.A.
 Tel: (727) 536-7831
 Fax: (727) 539-6882
 www.ametek.com/tci

